

# Analogue amplifier modules for 4/3 and 4/2 proportional directional valves 4WRE

**RE 30219/06.05**  
Replaces: 12.04

1/10

**Types VT-MRPA2 and VT-MRPA1**

Component series 1X



H6771

## Table of contents

Contents	Page
Features	1
Ordering code	2
Functional description	3
Block circuit diagram / pin assignment VT-MRPA2	4
Block circuit diagram / pin assignment VT-MRPA1	5
Technical data	6
Terminal assignment	7
Unit dimensions	7
Engineering / maintenance notes / supplementary information	8
Adjustment recommendations	9

## Features

- Suitable for controlling direct operated 4/3 and 4/2 proportional directional valves with electrical position feedback, type 4WRE, sizes 6 and 10, component series 2X
- Command value input  $\pm 10$  V (VT-MRPA2), 0 to 10 V (VT-MRPA1)
- Ramp generator with separately adjustable “up/down” ramp times
- Characteristic curve correction with symmetrically (with VT-MRPA2 only) adjustable step-change heights and separately (with VT-MRPA2 only) adjustable maximum values
- Enable input
- Reverse polarity protection of power supply
- Power supply unit with DC/DC converter without raised zero point
- Cable break detection in the position transducer branch
- LED indicator lamps:
  - Readiness for operation (green)
  - Enable (yellow)

## Ordering code

---

VT-MRPA	-	-	1X	/	V0	/	*
---------	---	---	----	---	----	---	---

Analogue amplifier of modular design

For 4/2 proportional directional valves 4WRE  
(with one solenoid)

= 1

For 4/3 proportional directional valves 4WRE  
(with two solenoids)

= 2

For controlling valve 4WRE 6 (component series 2X)

= 1

For controlling valve 4WRE 10 (component series 2X)

= 2

Component series 10 to 19

= 1X

(10 to 19: unchanged technical data and pin assignment)

Further details in clear text

V0 =

Basic version

Suitable power supply unit:

- Type VT-NE30-2X, see RE 29929  
compact power supply unit 115/230 VAC → 24 VDC,  
108 VA

## Functional description

### General

The amplifier modules are to be snapped onto top hat rails according to EN 60715. The electrical connection is made by means of screw terminals. The modules are operated at 24V DC.

### Power supply unit [1]

The amplifier modules are provided with a power supply unit with switch-on current limiter. The power supply unit provides all internally required positive and negative supply voltages. The switch-on current limiter prevents high switch-on current peaks.

### Command value feedforward

The internal command value signal is generated from the sum [3] of the external command value signal applied to differential input [2] and the zero point offset (zero point potentiometer "Zw").

The following is valid for VT-MRPA2:

A positive command value causes an increase in current in solenoid "b" and hence a flow in the valve from P to A and from B to T.

A negative command value causes an increase in current in solenoid "a" and hence a flow in the valve from P to B and from A to T.

The following is valid for VT-MRPA1:

A positive command value causes an increase in current in the solenoid.

### Enable function [11]

The enable function is used to enable the current output stages and to pass the internal command value signal on to the ramp generator. The enable signal is indicated by an LED on the front panel. When the enable is granted, the internal command value changes over the set ramp time (with any command value selection). The valve does therefore not open suddenly when activated.

### Ramp generator [4]

The ramp generator limits the gradient of the control output. The downstream step functions and amplitude attenuators do not shorten or extend the ramp time.

Note on the adjustment and measurement of the ramp time:

Value at measuring socket "t<" or "t>"	$U_t$ in V	5	3	2
Current ramp time ( $\pm 20\%$ )	$t$ in ms	20	33	50

$U_t$ in V	1	0.5	0.3	0.2	0.1	0.05	0.03	0.02
$t$ in ms	100	200	333	500	1000	2000	3333	5000

The following is valid: 
$$t = \frac{100 \text{ V ms}}{U_t}$$

Example: Measured  $U_t = 5 \text{ V}$   
 results in  $t = \frac{100 \text{ V ms}}{5 \text{ V}} = 20 \text{ ms}$

### Characteristic curve generator [5]

The adjustable characteristic curve generator can be used to adjust step-change heights symmetrically (with VT-MRPA2 only) and maximum values for positive and negative signals separately (with VT-MRPA2 only) to suit the hydraulic requirements. The actual line of the characteristic curve through the zero point is not stepped, but linear.

### Amplitude limiter [6]

The internal command value is limited to approx.  $\pm 110\%$  (with VT-MRPA2) or  $+110\%$  (with VT-MRPA1) of the nominal range.

### Oscillator [9]

The oscillator generates the control signal for the inductive position transducer.

### Demodulator [10]

The demodulator generates the actual value signal of the valve spool position from the position transducer signal:  $\pm 100\% \triangleq \pm 10 \text{ V}$  (with VT-MRPA2) or  $+100\% \triangleq +10 \text{ V}$  (with VT-MRPA1), respectively

### Controller for valve spool position [7]

The position controller is optimised specifically to the valve.

### Current output stage [8]

The current output stage generates the clocked solenoid current for the proportional valve. The solenoid current is limited to 2.4 A to 2.6 A per output. The output stage outputs are short-circuit-proof. In the event of an internal fault signal or missing enable, the output stages are de-energised.

### Fault detection [14]

The position transducer cable is monitored for cable break and primary-sided short-circuit, and the output stage for overcurrent.

[ ] = Cross-reference to block circuit diagrams on pages 4 and 5

Block circuit diagram / pin assignment VT-MRPA2

A positive command value causes an increase in current in solenoid "b" and hence a flow in the valve from P to A and from B to T.  
 A negative command value causes an increase in current in solenoid "a" and hence a flow in the valve from P to B and from A to T.

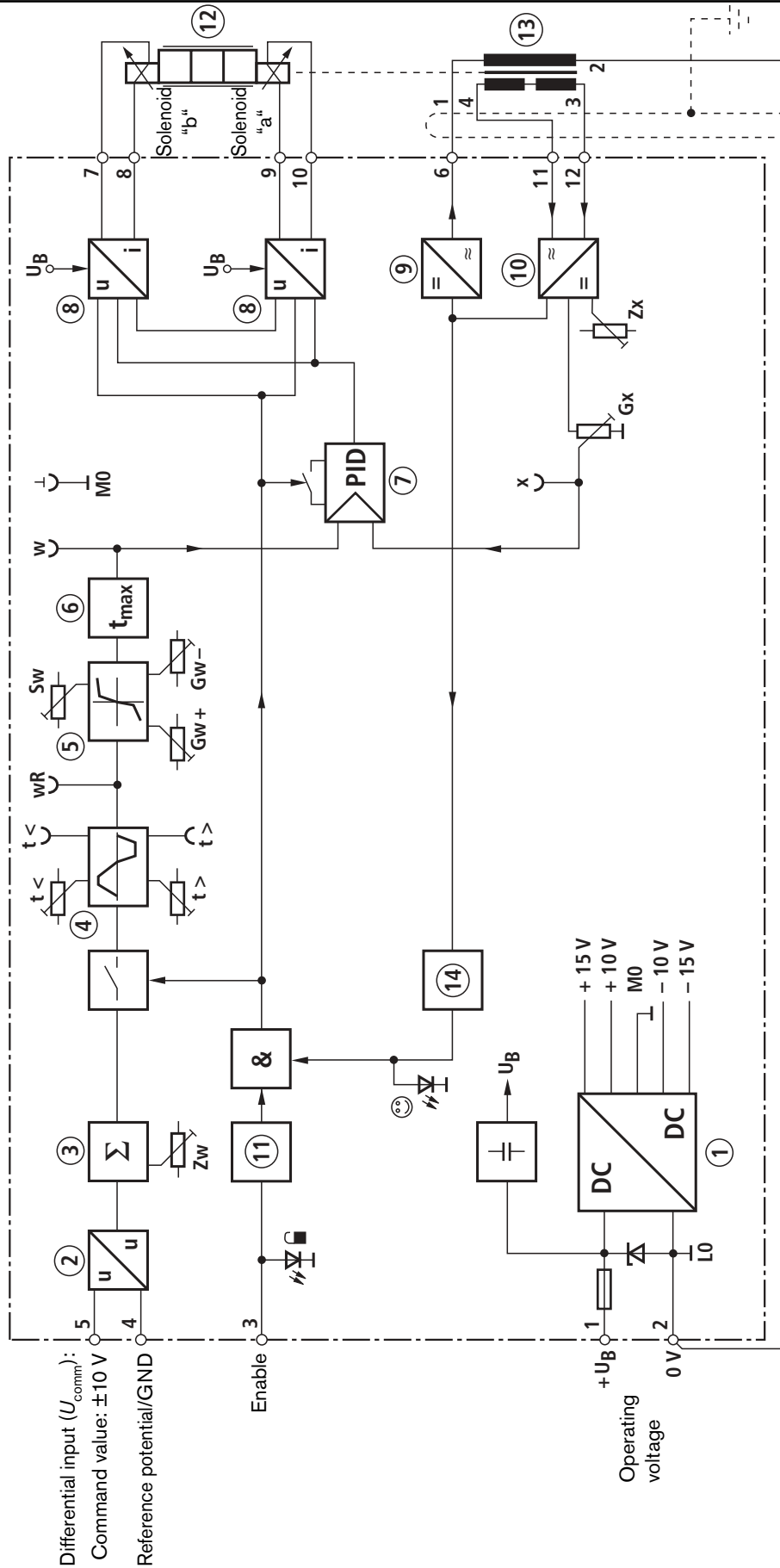

- Zw** = Command value zero point
- Zx** = Actual value zero point
- t<** = Ramp time "up"
- t>** = Ramp time "down"
- Sw** = Step-change height
- Gw** = Amplitude attenuator
- Gx** = Actual value sensitivity
- w** = Command value
- x** = Actual value
- wR** = Command value after ramp
- ☺ = Readiness for operation
- 🔒 = Enable
- 1** = Power supply unit
- 2** = Differential amplifier
- 3** = Command value summator
- 4** = Ramp generator
- 5** = Characteristic curve generator
- 6** = Amplitude limiter
- 7** = Controller for valve spool position
- 8** = Current output stage
- 9** = Oscillator
- 10** = Demodulator
- 11** = Enable function
- 12** = Proportional valve
- 13** = Inductive position transducer
- 14** = Fault detection

Block circuit diagram / pin assignment VT-MRPA1

A positive command value causes an increase in current in the solenoid

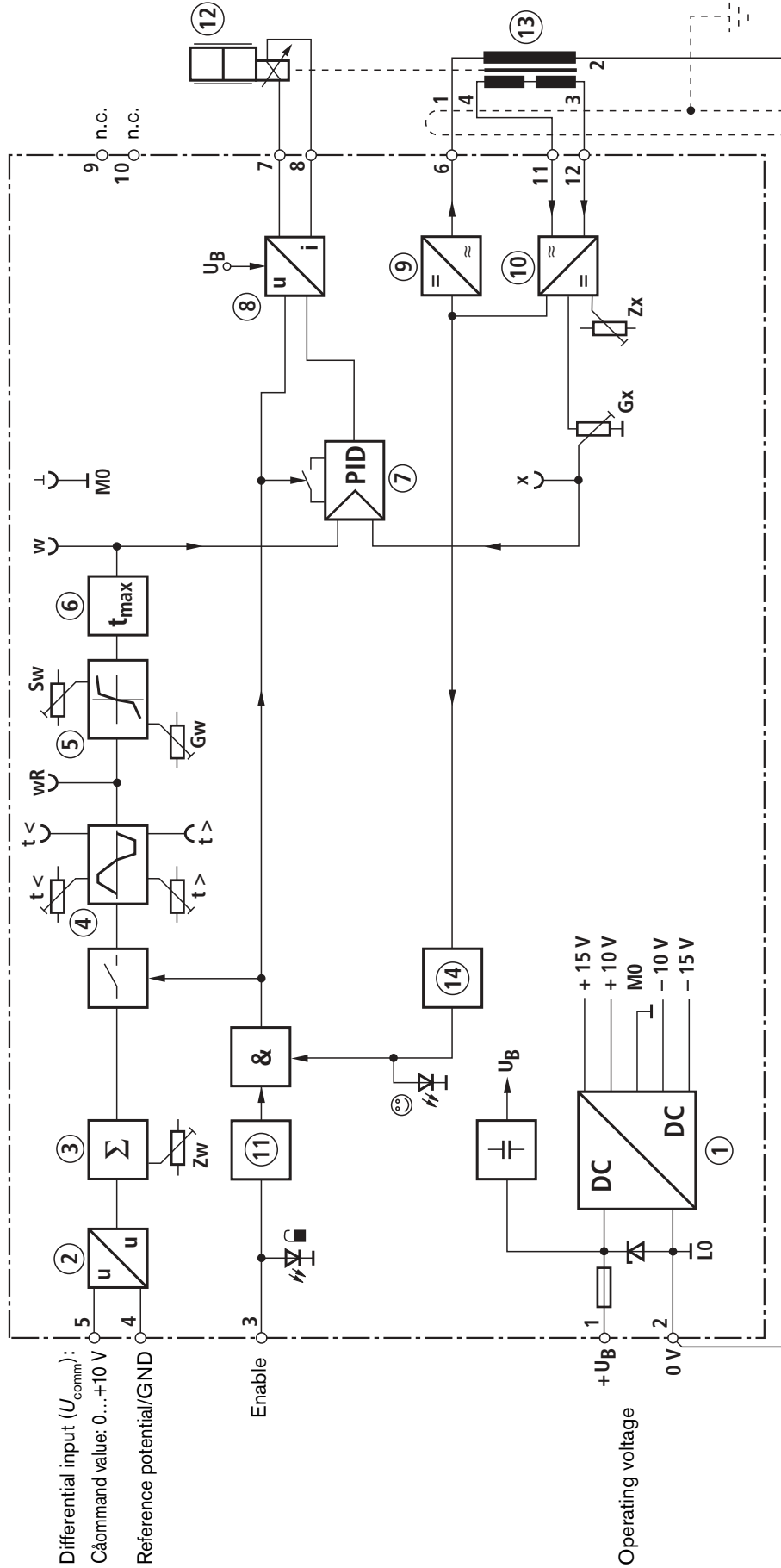

- |     |   |                          |    |   |                          |   |                                     |    |                               |
|-----|---|--------------------------|----|---|--------------------------|---|-------------------------------------|----|-------------------------------|
| Zw  | = | Command value zero point | Gx | = | Actual value sensitivity | 1 | Power supply unit                   | 8  | Current output stage          |
| Zx  | = | Actual value zero point  | w  | = | Command value            | 2 | Differential amplifier              | 9  | Oscillator                    |
| t < | = | Ramp time "up"           | x  | = | Actual value             | 3 | Command value summing               | 10 | Demodulator                   |
| t > | = | Ramp time "down"         | wR | = | Command value after ramp | 4 | Ramp generator                      | 11 | Enable function               |
| Sw  | = | Step-change height       | ☺  | = | Readiness for operation  | 5 | Characteristic curve generator      | 12 | Proportional valve            |
| Gw  | = | Amplitude attenuator     | 🔒  | = | Enable                   | 6 | Amplitude limiter                   | 13 | Inductive position transducer |
|     |   |                          |    |   |                          | 7 | Controller for valve spool position | 14 | Fault detection               |

**Technical data** (for applications outside these parameters, please consult us!)

Operating voltage	$U_O$	24 VDC + 40 % – 20 %
Operating range:		
– Upper limit value	$u_O(t)_{\max}$	35 V
– Lower limit value	$u_O(t)_{\min}$	18 V
Power consumption	$P_S$	< 24 VA
Current consumption	$I$	< 2 A
Fuse protection		Thermal overload protection (reclosing when the temperature falls below the threshold)
Inputs:		
– Analogue		
• Command value (differential input)	VT-MRPA2 VT-MRPA1	$U_i$ 0 to $\pm 10$ V, $R_i > 50$ k $\Omega$ (current input on enquiry) $U_i$ 0 to +10 V, $R_i > 50$ k $\Omega$ (current input on enquiry)
– Digital		
• Enable	ON	$U$ 8.5 V to $U_O$ , $R_i > 100$ k $\Omega$
	OFF	$U$ 0 to 6.5 V, $R_i > 100$ k $\Omega$
Adjustment ranges:		
– Command value zero point (potentiometer "Zw")		$\pm 30$ %
– Actual value zero point (potentiometer "Zx")		$\pm 10$ %
– Ramp times (potentiometers "t <" and "t >")		20 ms to 5 s
– Step-change height (potentiometer "Sw")		0 % to 50 %
– Amplitude attenuator (potentiometers "G+" and "G-")		0 % to 110 % (valid for a step-change height setting of 0 %)
Outputs:		
– Current outputs	$I$	0 to 2.5 A; short-circuit-proof; clocked, approx. 5 kHz
– Oscillator	$U_{SS}$ $f$	10 V; 10 mA 5.6 kHz $\pm 10$ %
– Measuring sockets		
• Ramp time "t <"		$U$ 20 mV to 5 V
• Ramp time "t >"		$U$ 20 mV to 5 V
• Actual value "x"	VT-MRPA2 VT-MRPA1	$U$ 0 to $\pm 10$ V $U$ 0 to +10 V
• Command value "w"	VT-MRPA2 VT-MRPA1	$U$ 0 to $\pm 10$ V $U$ 0 to +10 V
• Command value after ramp "wR"	VT-MRPA2 VT-MRPA1	$U$ 0 to $\pm 10$ V $U$ 0 to –10 V
Type of connection		12 screw terminals
Type of mounting		Top hat rail TH 35-7.5 to EN 60715
Type of protection		IP 20 to EN 60529
Dimensions (W x H x D)		40 x 79 x 85.5 mm
Permissible operating temperature range	$\vartheta$	0 to +50 °C
Storage temperature range	$\vartheta$	–25 to +70 °C
Weight	$m$	0.14 kg

 **Note!**

Details with regard to **environment simulation testing** in the fields of EMC (electromagnetic compatibility), climate and mechanical stress, see RE 30219-U (declaration on environmental compatibility).

## Terminal assignment

				VT-MRPA2	VT-MRPA1
Operating voltage	$+U_O$	1	7	Solenoid "b"	Solenoid
	0 V <sup>1)</sup>	2	8		
Enable	$U_E$	3	9	Solenoid "a"	n.c.
Differential input	Reference potential	4	10		
	$\pm U_{comm}$	5	11	4 Position transducer, secondary	4 Position transducer, secondary
Position transducer, primary	1	6	12	3	3

<sup>1)</sup> and position transducer, primary (connection 2)

## Unit dimensions (nominal dimensions in mm)

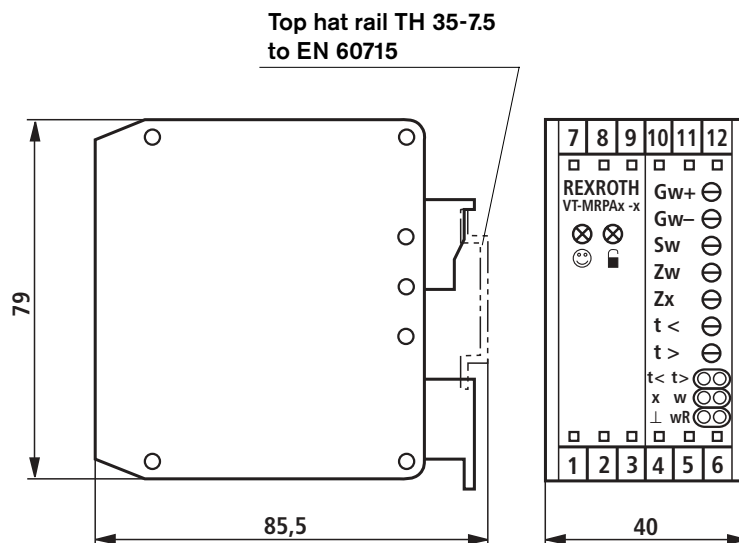

### LED indicator lamps:

- ☺ Readiness for operation (green)
- 🔒 Enable (yellow)

### Potentiometers:

- Gw+** Amplitude attenuator for positive command values
- Gw-** Amplitude attenuator for negative command values (only with VT-MRPA2)
- Sw** Step-change height for negative and positive direction
- Zw** Command value zero point
- Zx** Actual value zero point
- t <** Ramp time for rising command values
- t >** Ramp time for falling command values

### Measuring sockets:

- t <** Ramp time "up"
- t >** Ramp time "down"
- x** Actual value
- w** Command value
- wR** Command value after ramp
- ⊥** Measuring zero

## Engineering / maintenance notes / supplementary information

---

- The amplifier module may only be wired when disconnected from the power supply!
- Do not lay cables near power cables!
- Do not use free-wheeling diodes in solenoid cables!
- The distance to aerial lines, radio sources and radar equipment must be at least 1 m!
- Always shield command value and position transducer cables; connect the shield to the protective earth (PE) on the module side!  
In individual cases (e.g. in the case of PE with severe interference) it may be required to connect the shield of the position transducer cable directly to LO of the amplifier module; leave the other end open (risk of earth loops).  
Recommendation: Also shield solenoid cables!  
For solenoid cables up to 50 m length, use cable type LiYCY 1.5 mm<sup>2</sup>!  
For greater lengths, please consult us!
- For passing on command values, use relays with gold-plated contacts (small voltages, small currents)!
- Measurements on the module may only be taken with instruments  $R_i > 100 \text{ k}\Omega$ .
- To adjust the potentiometers, use a screw driver with a blade width of 4 mm!
- In the case of strongly fluctuating operating voltages, it may be required to install an external smoothing capacitor having a capacitance of at least 2200  $\mu\text{F}$ .  
Recommendation: Capacitor module VT 11073 (see RE 29750), sufficient for up to 3 amplifier modules



## Adjustment recommendation

The system-specific circuitry must be completed.

Signal	Setting for VT-MRPA2	Setting for VT-MRPA1
Command value zero point	<ul style="list-style-type: none"> <li>– Set external command value feedforward to zero</li> <li>– Set the internal command value to zero using zero point potentiometer "Zw" and check the setting at measuring socket "wR"</li> </ul>	<ul style="list-style-type: none"> <li>– Set external command value feedforward to zero</li> <li>– Set the internal command value to zero using zero point potentiometer "Zw" and check the setting at measuring socket "wR"</li> </ul>
Actual value zero point	<ul style="list-style-type: none"> <li>– Set enable signal to "OFF" or disconnect solenoid plug-in connector (Valve moves to the mechanical centred position)</li> <li>– Set the actual value at measuring socket "x" to zero using potentiometer "Zx"</li> </ul> <p>Recommendation: In the case of valves with V-spools, adjust the zero point during operation with the hydraulic drive, i.e.</p> <ul style="list-style-type: none"> <li>– Apply enable signal and check at measuring sockets "wR" and "w"</li> <li>– Use potentiometer "Zx" to bring the hydraulic drive to a standstill</li> </ul>	<ul style="list-style-type: none"> <li>– Set enable signal to "OFF" or disconnect solenoid plug-in connector (Valve moves to end position)</li> <li>– Set the actual value at measuring socket "x" to zero using potentiometer "Zx"</li> </ul> <p>Recommendation: In the case of valves with V-spools, adjust the zero point during operation with the hydraulic drive, i.e.</p> <ul style="list-style-type: none"> <li>– Apply enable signal and check at measuring sockets "wR" and "w"</li> <li>– Use potentiometer "Zx" to bring the hydraulic drive to a standstill</li> </ul>
Ramp times	<ul style="list-style-type: none"> <li>– Set ramp time according to formula or table (see functional description "Ramp generator") and check at measuring sockets "t &gt;" and "t &lt;"</li> </ul>	<ul style="list-style-type: none"> <li>– Set ramp time according to formula or table (see functional description "Ramp generator") and check at measuring sockets "t &gt;" and "t &lt;"</li> </ul>
Step-change height	<ul style="list-style-type: none"> <li>– Apply enable signal</li> <li>– Set the measuring signal at "wR" to +0.3 V using zero point potentiometer "Zw"</li> <li>– Set the required step-change height using potentiometer "Sw"</li> <li>– Set the measuring signal at "wR" to –0.3 V using zero point potentiometer "Zw"</li> <li>– Check the required step-change height, adjust zero point</li> </ul> <p>Note: In the case of an external command value feedforward, at least +0.3 V / –0.3 V must be measured at measuring socket "wR".</p>	<ul style="list-style-type: none"> <li>– Apply enable signal</li> <li>– Set the measuring signal at "wR" to –0.3 V using zero point potentiometer "Zw"</li> <li>– Set the required step-change height using potentiometer "Sw"</li> <li>– Check the required step-change height, adjust zero point</li> </ul> <p>Note: In the case of an external command value feedforward, at least –0.3 V must be measured at measuring socket "wR"</p>
Maximum values	<p>Note: Before the maximum values are matched, the zero point and step-change heights must have been correctly set.</p> <ul style="list-style-type: none"> <li>– Adjust step-change heights first; generate <math>\pm 100\%</math> command value externally</li> <li>– Use potentiometers "Gw+/" "Gw–" to adjust the required maximum control output and check the settings at measuring sockets "wR" and "w"</li> </ul>	<p>Note: Before the maximum values are matched, the zero point and step-change heights must have been correctly set.</p> <ul style="list-style-type: none"> <li>– Adjust step-change heights first; generate +100 % command value externally</li> <li>– Use potentiometer "Gw" to adjust the required maximum control output and check the settings at measuring sockets "wR" and "w"</li> </ul>

## Notes

---

Bosch Rexroth AG  
Hydraulics  
Zum Eisengießer 1  
97816 Lohr am Main, Germany  
Phone +49 (0) 93 52 / 18-0  
Fax, +49 (0) 93 52 / 18-23 58  
documentation@boschrexroth.de  
www.boschrexroth.de

© This document, as well as the data, specifications and other information set forth in it, are the exclusive property of Bosch Rexroth AG. It may not be reproduced or given to third parties without its consent.

The data specified above only serve to describe the product. No statements concerning a certain condition or suitability for a certain application can be derived from our information. The information given does not release the user from the obligation of own judgment and verification. It must be remembered that our products are subject to a natural process of wear and aging.

## Notes

---

Bosch Rexroth AG  
Hydraulics  
Zum Eisengießer 1  
97816 Lohr am Main, Germany  
Phone +49 (0) 93 52 / 18-0  
Fax +49 (0) 93 52 / 18-23 58  
documentation@boschrexroth.de  
www.boschrexroth.de

© This document, as well as the data, specifications and other information set forth in it, are the exclusive property of Bosch Rexroth AG. It may not be reproduced or given to third parties without its consent.

The data specified above only serve to describe the product. No statements concerning a certain condition or suitability for a certain application can be derived from our information. The information given does not release the user from the obligation of own judgment and verification. It must be remembered that our products are subject to a natural process of wear and aging.

## Notes

---

Bosch Rexroth AG  
Hydraulics  
Zum Eisengießer 1  
97816 Lohr am Main, Germany  
Phone +49 (0) 93 52 / 18-0  
Fax, +49 (0) 93 52 / 18-23 58  
documentation@boschrexroth.de  
www.boschrexroth.de

© This document, as well as the data, specifications and other information set forth in it, are the exclusive property of Bosch Rexroth AG. It may not be reproduced or given to third parties without its consent.

The data specified above only serve to describe the product. No statements concerning a certain condition or suitability for a certain application can be derived from our information. The information given does not release the user from the obligation of own judgment and verification. It must be remembered that our products are subject to a natural process of wear and aging.