

Check valve, cartridge design Type M-SR



- ▶ For installation in block designs as angle valve
- ▶ Size 8 ... 30
- ▶ Series 1X
- ▶ Maximum operating pressure 420 bar
- ▶ Maximum flow 400 l/min

Features

- ▶ Leakage-free blocking in one direction
- ▶ Various cracking pressures, optional (see type code)

Contents

Type code	2
Functional description	3
Technical data	4
Characteristic curves	5
Installation bore	6
Related documentation	9

Type code

01	02	03	04	05	06	07
M-SR		KE	/	1X	/	*

01	Check valve, cartridge design	M-SR
----	-------------------------------	-------------

Size (NG)

02	Size 8	8
	Size 10	10
	Size 15	15
	Size 20	20
	Size 25	25
	Size 30	30

Unit design

03	Angle valve	KE
----	-------------	-----------

Cracking pressure (see characteristic curves page 5)

04	0 bar; without spring	00
	0.2 bar	02
	0.5 bar (standard)	05
	1.5 bar	15
	3.0 bar	30
	5.0 bar	50

Series

05	Series 10 ... 19 (10 ... 19: unchanged installation and connection dimensions)	1X
----	--	-----------

Sealing material

06	NBR (nitrile rubber) (without designation)	
	FKM (fluoroelastomer)	V

07	Further details in the plain text	*
----	-----------------------------------	---

Functional description

▼ Sectional view

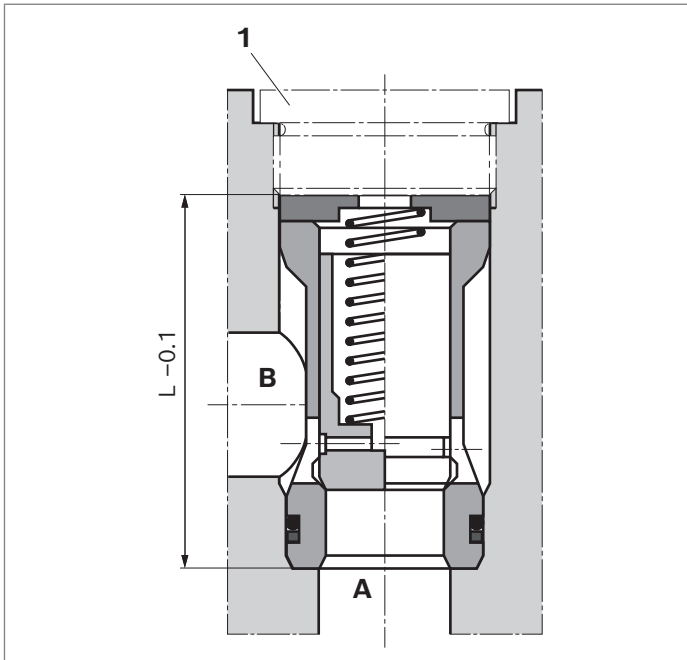

1 Plug screw, separate order, see page 6 to 8

▼ Symbol

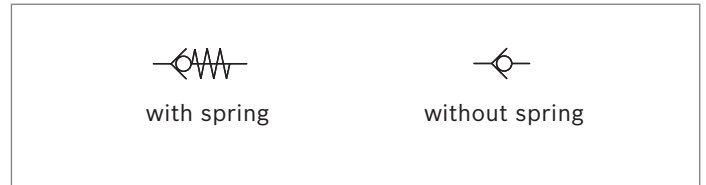

Size	L _{-0.1}
8	36.3
10	39.3
15	45.8
20	55.3
25	74.3
30	83.3

Technical data

General	Size (NG)	8	10	15	20	25	30
Weight	kg	0.03	0.05	0.08	0.14	0.32	0.47
Installation position		Any					
Ambient temperature range	°C	-20 ... +80 (NBR seals) -20 ... +80 (FKM seals)					
MTTF _D value according to EN ISO 13849	Years	150 (for further details see data sheet 90294)					

Hydraulic		
Maximum operating pressure	bar	420
Cracking pressure	bar	See characteristic curves page 5
Maximum flow	l/min	See characteristic curves page 5
Hydraulic fluid		See table below
Hydraulic fluid temperature range	°C	-30 ... +80 (for NBR seals) -20 ... +80 (for FKM seals)
Viscosity range	mm ² /s	2.8 ... 500
Maximum admissible degree of contamination of the hydraulic fluid Cleanliness level according to ISO 406 (c)		Level 20/18/15 ¹⁾

Notice

For applications outside these parameters, please consult us!

¹⁾ Cleanliness levels specified for the components must be maintained in the hydraulic systems. Effective filtration prevents malfunctions and simultaneously extends the service life of the components.

Hydraulic fluid

Hydraulic fluid		Classification	Suitable sealing materials	Standards	Data sheet
Mineral oils		HL, HLP	NBR, FKM	DIN 51524	90220
Environmentally acceptable	Insoluble in water	HETG, HEES	FKM	ISO 15380	90221
	Soluble in water	HEPG	FKM	ISO 15380	90221
Flame-resistant	Water-free	HFDU (glycol-based), HFDU (ester base)	FKM	ISO 12922	90222
	Containing water	HFC (Fuchs Hydrotherm 46M, Petrofer Ultra Safe 620)	NBR	ISO 12922	20223

Notice

- ▶ Further information and details on using other hydraulic fluids are available in the above data sheets or on request.
- ▶ Restrictions are possible with the technical valve data (temperature, pressure range, service life, maintenance intervals, etc.)!

- ▶ **Environmentally acceptable:** If environmentally acceptable hydraulic fluids are used that are also zinc-solvent, there may be an accumulation of zinc.
- ▶ **Flame-resistant – containing water:**
 - Life cycle as compared to operation with mineral oil HL, HLP 30 ... 100%
 - Maximum hydraulic fluid temperature 60 °C

Characteristic curves

Pressure differential Δp dependent on the flow q_v at cracking pressure

▼ Size 8

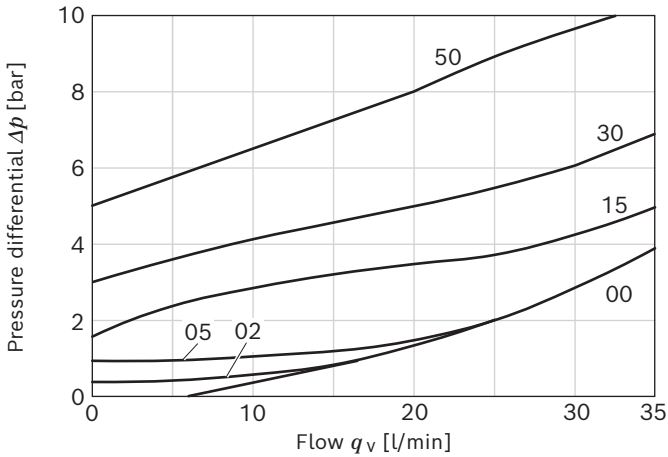

▼ Size 20

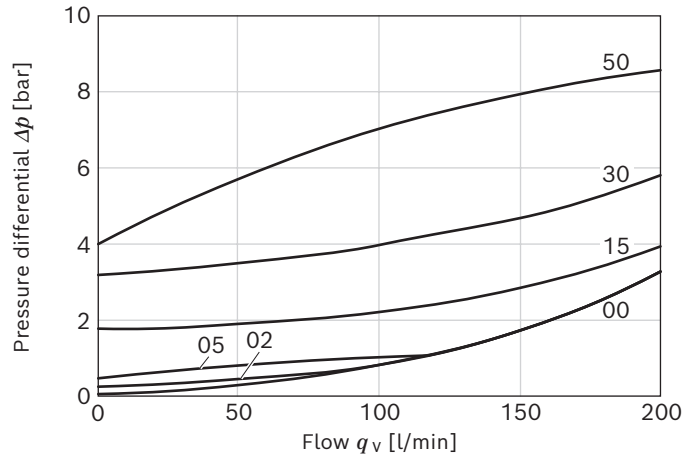

▼ Size 10

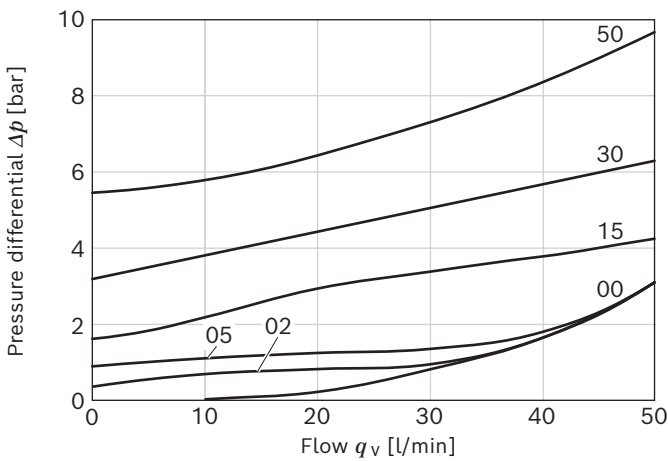

▼ Size 25

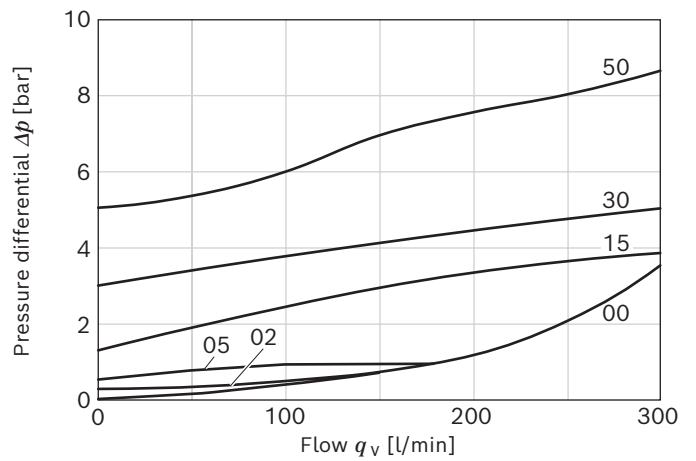

▼ Size 15

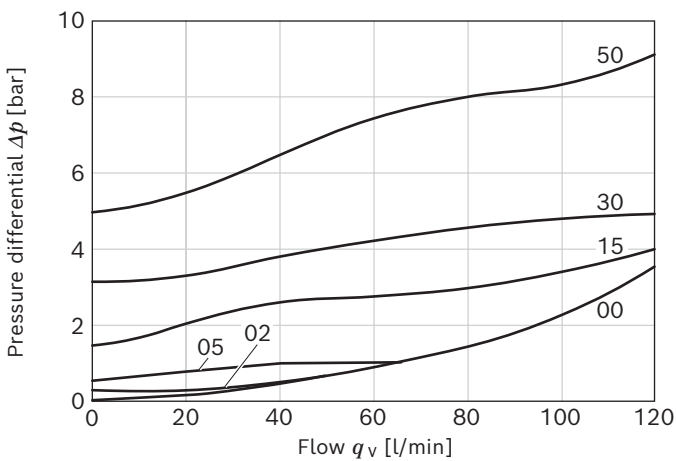

▼ Size 30

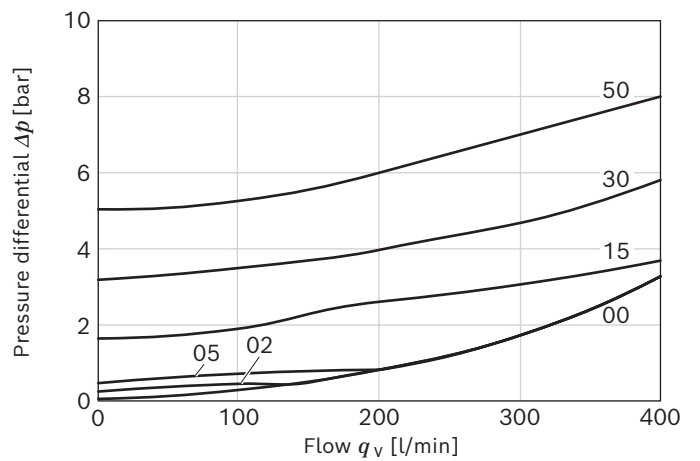

Notice

Characteristic curves measured with HLP46, $\vartheta_{oil} = 40 \pm 5 \text{ }^\circ\text{C}$.

Installation bore

▼ Angle valve "KE" for threaded plug according to ZN 10001

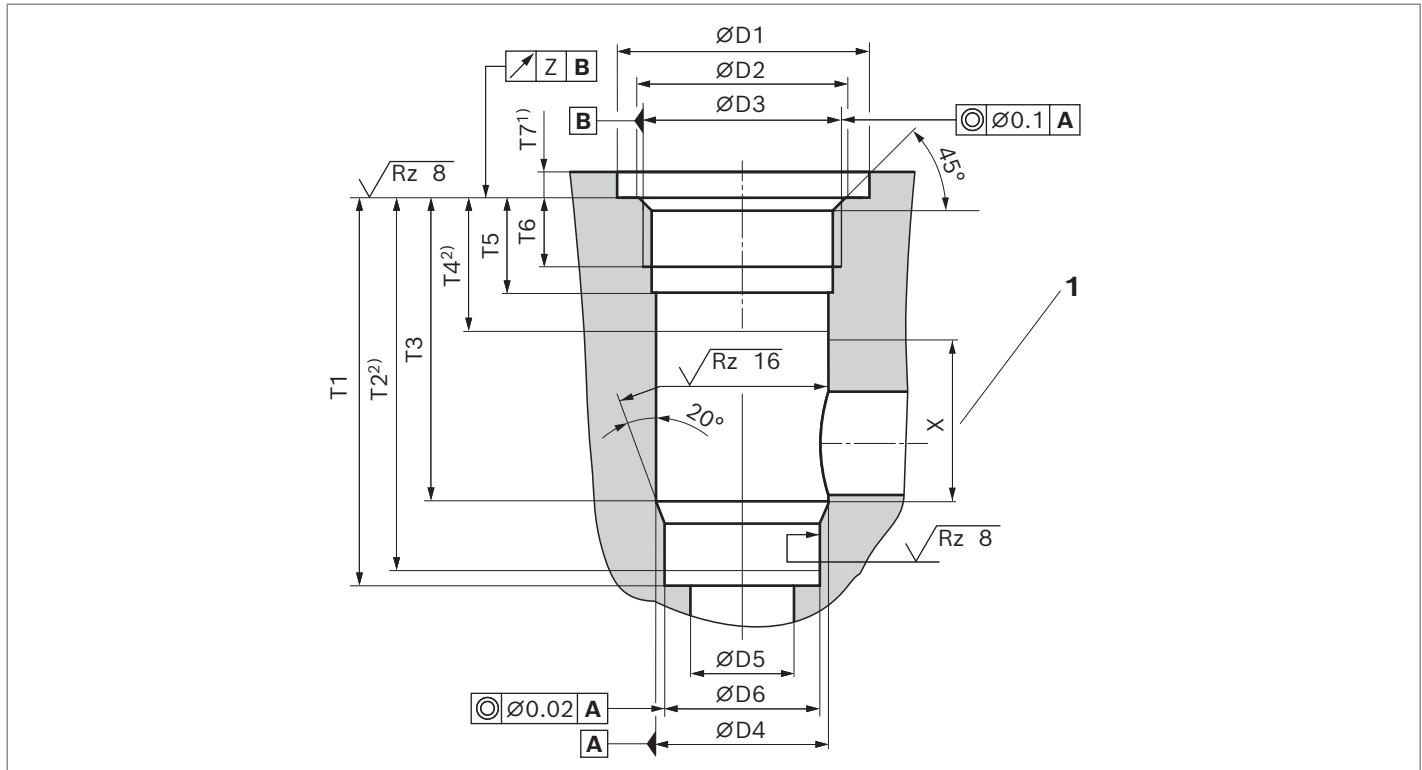

1 Area for outlet bore

NG	Threaded plugs – Material no. ³⁾			p_{Nom} [bar]	ØD1	ØD2	D3 ⁴⁾	ØD4H8	ØD5	ØD6H7
	NBR	FKM	$M_A \pm 10\%$ [Nm]							
8	R913011602	R913011610	55	420	23	17.1	G 3/8	14	8	13
10	R913011603	R913011611	80	420	28	21.4	G 1/2	18	10	17
15	R913011604	R913011612	135	420	33	26.8	G 3/4	24	15	22
20	R913011605	R913011613	225	420	41	33.8	G 1	30	20	28
25	R913011606	R913011614	360	250	51	42.5	G 1 1/4	38	25	36
30	R913011607	R913011615	400	250	56	48.5	G 1 1/2	44	30	42

NG	T1 ^{+0.1}	T2	T3	T4	T5	T6	T7 ^{+0.5}	T8 ^{+0.2}	X	Z
8	48.5	47.5	38.5	20	15	12	6	–	18	0.05
10	53.5	52.5	43.5	24	18	14	6	–	19	0.05
15	62	60.5	50	26	20.5	16	6	–	24	0.05
20	71.5	70	56.5	26	20.5	16	7	–	30	0.05
25	90.5	88	72.5	28	22	16	7	–	43	0.1
30	99.5	96.5	79.5	31	22	16	7	–	48	0.1

1) Dimension for countersinking the screw head. For lower installation of the installation kit, dimension T7 is to be extended accordingly.

2) Depth of fit

3) Separate order. It is recommended to oil the threaded plugs.

4) Pipe thread according to ISO 228/1

▼ Angle valve "KE" for threaded plug according to RN 143.28 – up to 315 bar

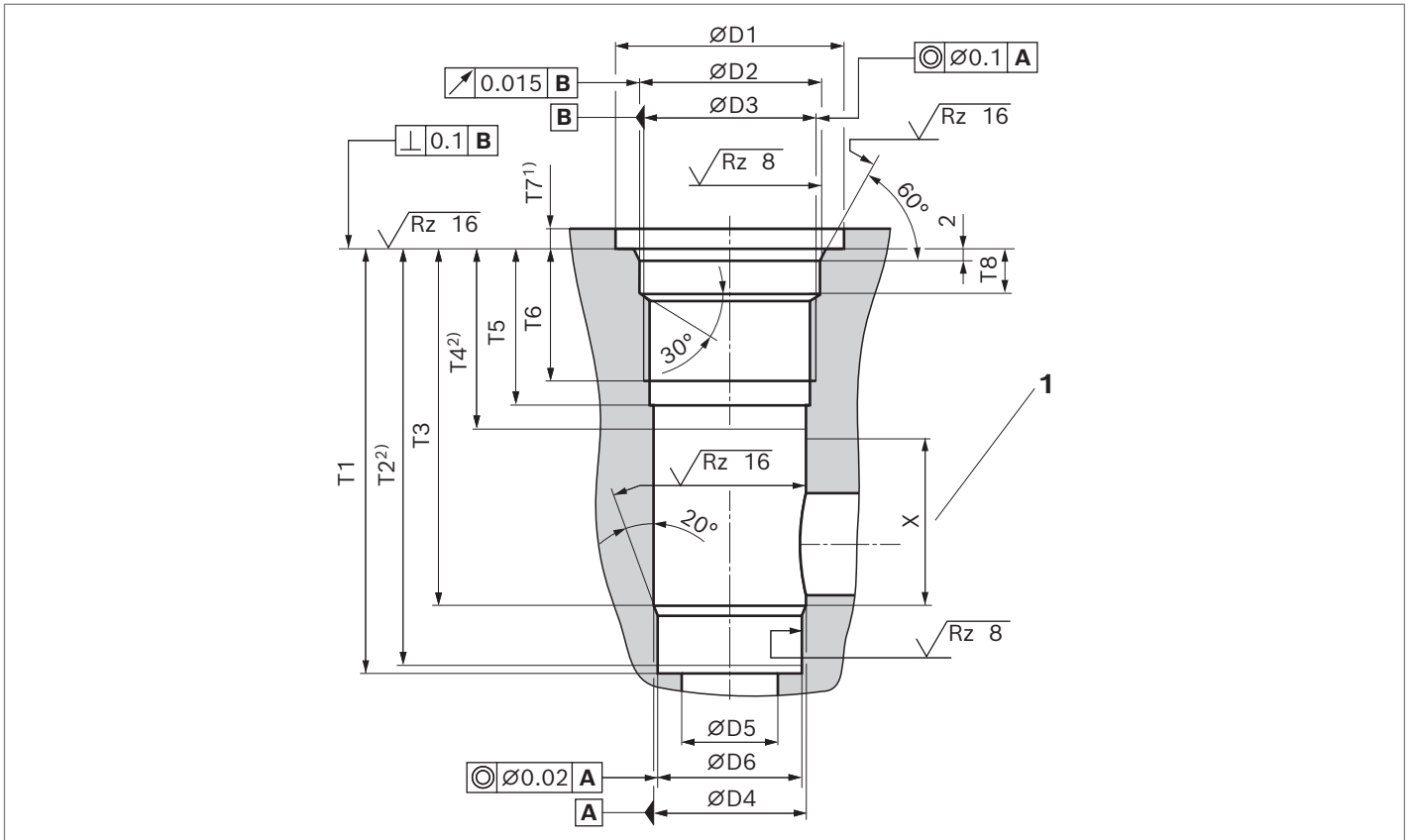

1 Area for outlet bore

NG	Threaded plugs – Material no. ³⁾			p_{Nom} [bar]	ØD1	ØD2	D3 ⁴⁾	ØD4H8	ØD5	ØD6H7
	NBR	FKM	$M_A \pm 10\%$ [Nm]							
25	R900323609	R900301957	300	315	56+0.5	44	M42×1.5	38	25	36
30	R900323610	R900301958	325	315	62+0.5	50	M48×1.5	44	30	42

NG	T1 ^{+0.1}	T2	T3	T4	T5	T6	T7 ^{+0.5}	T8 ^{+0.2}	X	Z
25	106.5	104	88.5	45	39	33	5	12	43	–
30	115.5	112.5	95.5	48	39	33	5	12	48	–

1) Dimension for countersinking the screw head. For lower installation of the installation kit, dimension T7 is to be extended accordingly.

2) Depth of fit

3) Separate order, to be replaced in case of maintenance.

4) Metric ISO fine thread according to DIN 13

▼ **Angle valve "KE" for plug screw according to RN 143.28 – up to 420 bar**

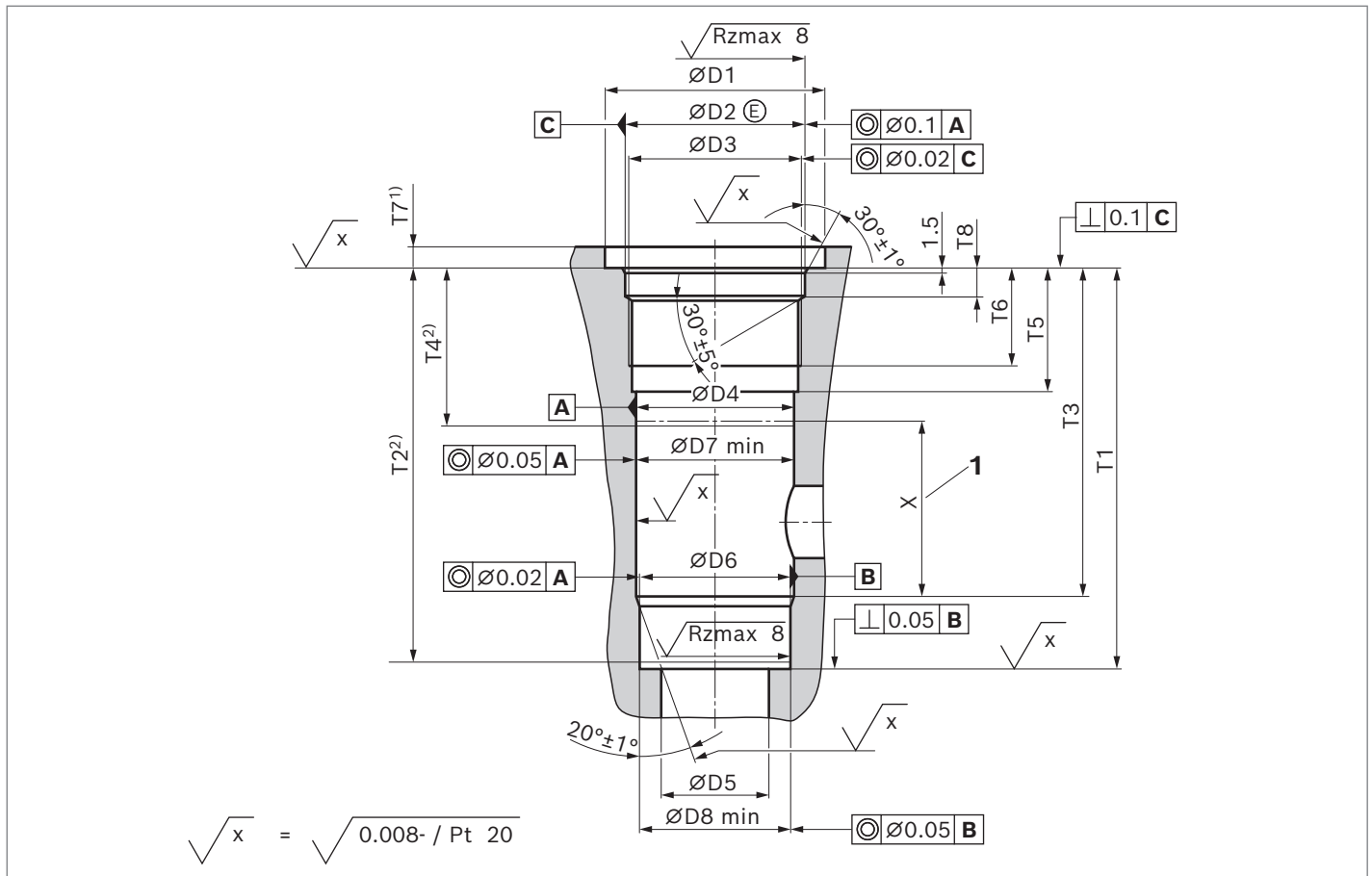

1 Area for outlet bore

NG	Threaded plugs – Material no. ³⁾			p_{Nom} [bar]	ØD1	ØD2H8	D3 ⁴⁾	ØD4H8	ØD5	ØD6H7	ØD7	ØD8
	NBR	FKM	$M_A \pm 10\%$ [Nm]									
25	R901183335	R901253503	300	420	51+0.5	44	M42×2	38	25	36	37.58	35.58
30	R901183336	R901253504	325	420	61+0.5	50	M48×2	44	30	42	43.58	41.58

NG	T1 ^{+0.1}	T2 min	T3	T4 min	T5	T6 ⁺¹	T7 ^{+0.5}	T8 ^{+0.2}	X
25	101.5	100	83.5	40	34	27	6	7.8	43
30	110.5	108.5	90.5	43	34	27	6	7.8	48

Notice

From an operating pressure greater than 350 bar, the threaded plug must be glued with Loctite 243 over the entire thread circumference.

1) Dimension for countersinking the screw head. For lower installation of the installation kit, dimension T7 is to be extended accordingly.

2) Depth of fit

3) Separate order, to be replaced in case of maintenance.

4) Metric ISO fine thread according to DIN 13

Related documentation

- ▶ Mineral oil-based hydraulic fluids
- ▶ Environmentally acceptable hydraulic fluids
- ▶ Fire-resistant, water-free hydraulic fluids
- ▶ Fire-resistant hydraulic fluids – containing water (HFAE, HFAS, HFB, HFC)
- ▶ Reliability coefficients according to EN ISO 13849
- ▶ Hydraulic valves for industrial applications
- ▶ Information on available spare parts

Data sheet 90220

Data sheet 90221

Data sheet 90222

Data sheet 90223

Data sheet 90294

Operating instructions 07600-B

www.boschrexroth.com/spc

Bosch Rexroth AG

Zum Eisengießer 1
97816 Lohr am Main
Germany
Phone +49 9352 18-0
info.ma@boschrexroth.de
www.boschrexroth.com

© Bosch Rexroth AG 2020. All rights reserved, also regarding any disposal, exploitation, reproduction, editing, distribution as well as in the event of applications for industrial property rights. The data specified within only serves to describe the product. No statements concerning a certain condition or suitability for a certain application can be derived from our information. The information given does not release the user from the obligation of own judgment and verification. It must be remembered that our products are subject to a natural process of wear and aging.